

On Knots and Planar Connected Graphs

Evert Stenlund

August 2016

<http://evertstenlund.se/knots/>

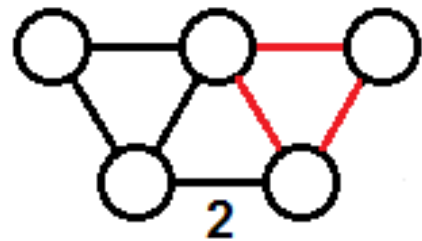
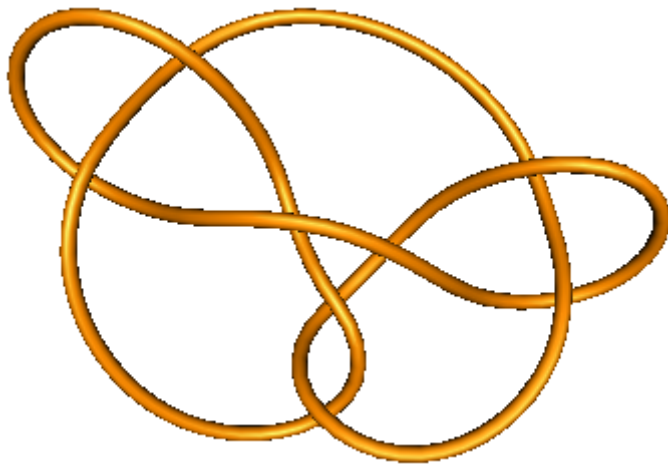

1. Introduction

If a piece of string is tied and joined at its ends a mathematical knot is formed. In most cases the knot cannot be untied unless the ends are separated again. The field of mathematical knots deals with questions such as whether a knot can be untied or not or whether two knots are the same or not. [1,2,3] In this note we will discuss how to represent prime knots as planar connected graphs [4].

2. The trefoil knot

The simplest nontrivial knot is the trefoil knot, in which, in its simplest form, the string crosses itself three times. Different versions of this knot are shown in figure 1. Knot 1a can be transformed to coincide with knot 1c, and the knots 1b and 1d have the same relationship. Knot 1b, which is the mirror image of knot 1a, cannot be transformed to coincide with knots 1a or 1c. The trefoil knot has alternating crossings, since, if we follow the string around, the crossings alternate between over- and under-crossings. The trefoil knot is denoted 3_1 [5]. The knot images shown in this and other figures are drawn using KnotPlot [6].

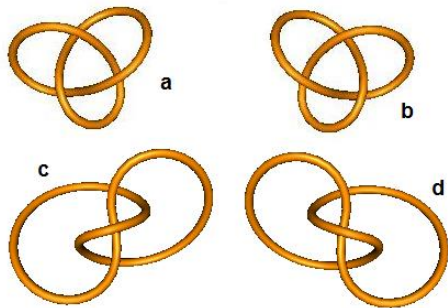

Figure 1: The trefoil knot

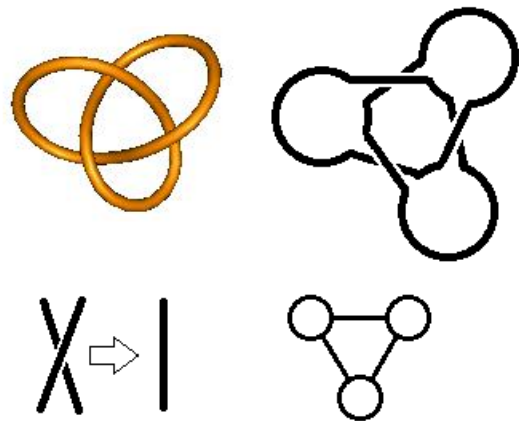

Figure 2: The trefoil graph I

3. The trefoil graphs

In figure 2 the trefoil knot is deformed to make a connected graph with three nodes and three edges. Firstly the three crossings are squeezed together to make elongated X-es and the rest of the string is rounded off to circles. Finally the X-es are replaced by edges to form the graph.

In figure 3 one strand is lifted over the knot which is then deformed into the form at the lower left. Again the crossings are squeezed together to make elongated X-es, but this time the X-es are the mirror images of the X-es in figure 2. In this case we can let the crossing be indicated by a red edge in the final graph. Black and red edges are said to have different parities.

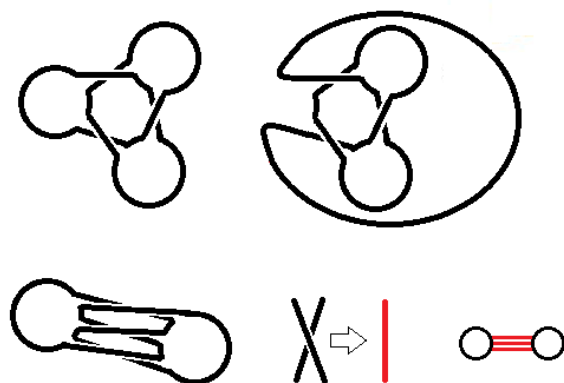

Figure 3: The trefoil graph II

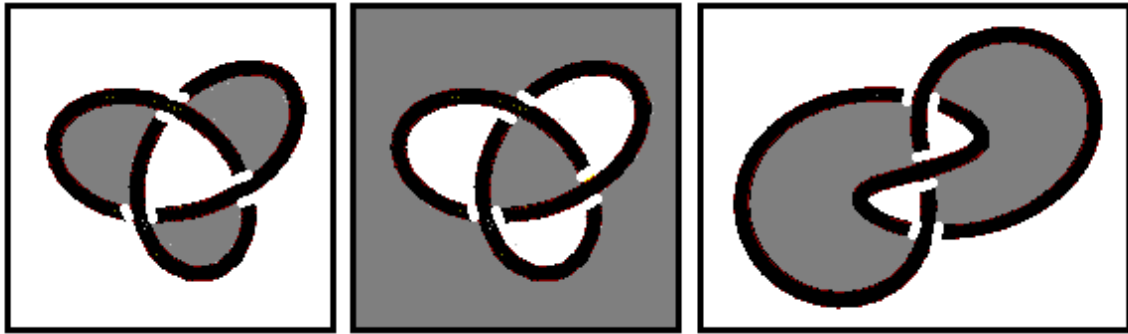

Figure 4: Shading of the trefoil knot

A convenient way to construct the knot graphs is to shade the different regions in the graph as in figure 4. Here all regions that are connected only through crossings are shaded and all other regions are left unshaded. If we regard the outside of the knot as one region, a knot with n crossings will have $n+2$ regions. Each representation of a knot will have two different shadings as indicated by the first two panels in figure 4. When moving from one shaded region to another through a crossing, the string piece coming from the left crosses over the string piece coming from the right (as in the first panel), the crossing is considered to be the one depicted in figure 2 and gives a black edge in the graph. If instead the string piece coming from the right crosses over the string piece coming from the left (as in the second and third panels) the crossing depicted in figure 3 will be obtained giving rise to a red edge in the graph. It should now be obvious that the first panel corresponds to the graph in figure 2, and that the shadings of the two other panels both will result in the graph in figure 3.

There are consequently four different graphs that can represent the trefoil knot. This is true for most graphs representing knots, but for some knots, some of the graphs will be the same. In figure 5 the two top graphs both correspond to knot a in figure 1, and the bottom two graphs both correspond to knot b. We call the two black graphs in figure 5 twin-graphs.

In what follows, unless otherwise stated, whenever we study alternating knots, corresponding to graphs with just one colour, we will only consider the graphs with black edges.

A further simplification of a graph is obtained when two nodes are connected by more than one edge as shown in figure 6a. A number beside an edge indicates the number of connections between the nodes. If a number is missing a single connection is intended. In the following we denote edges in a graph as bundles, and a bundle can carry any positive number indicating the number of connections between the two associated nodes. A bundle can also carry a negative number. This corresponds to a red-coloured bundle with the same positive

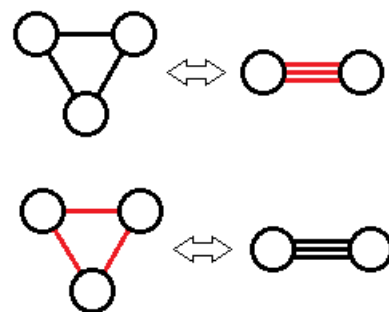

Figure 5: 4 graphs representing the trefoil knot



Figure 6a: Simplifying a graph

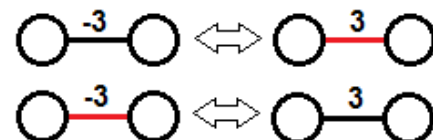

Figure 6b: Negative bundles

number (see figure 6b). In the following we will predominately use the red colour to indicate negative bundles.

4. The figure-8 knot

The trefoil knot is the only knot that can be transformed so that there are only three crossings. This is called the minimal crossing number of a knot. An alternating knot is always in its minimal state unless there are loops or twists that can easily be removed (c.f. the **R₁**-move below). The only knot with a minimal crossing number equal to 4 is the figure-8 knot shown in figure 7 together with its corresponding graph. When this knot is shaded in the same way as was done for the trefoil knot, both resulting graphs will look the same (an amphicheiral knot). The figure-8 knot is denoted **4₁** and its graph is its own twin.



Figure 7: The figure-8 knot and its graph

5. Transforming knots and graphs by Reidemeister moves

There are many ways to transform knots into new projections. All such transformations can be achieved by a sequence of so called Reidemeister moves [7]. The three Reidemeister moves are shown in figure 8. The first Reidemeister move, **R₁**, shows that a simple loop can be created or deleted at will. The second Reidemeister move, **R₂**, shows that one of two strands besides each other can be lifted on top of the other. The third Reidemeister move, **R₃**, shows that a third strand can be placed on either side of the crossing of two others.

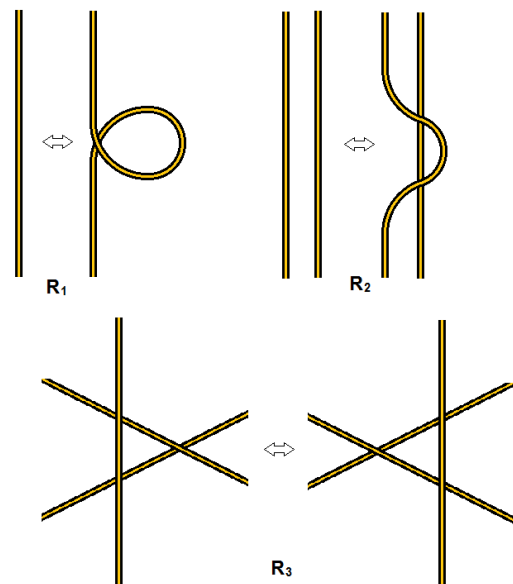

Figure 8: Reidemeister moves

The Reidemeister moves can easily be adapted to corresponding moves on graphs. As a consequence of the two ways to shade a knot each move can appear in two variations. The last Reidemeister move will however result in the same subgraphs. Figure 9 summarises the corresponding moves for graphs. The **R₁**-move results in removing or adding a loop that connects a node to itself, while leaving the rest of the graph intact. The same move can also result in removing or adding a node that only has one connection to the rest of the graph. The **R₂**-move results in removing or adding two edges of different parities that connect the same two nodes. It will also merge two nodes, both connected to the same third node but with different parities. The node in the middle may not be connected to other nodes in the graph.

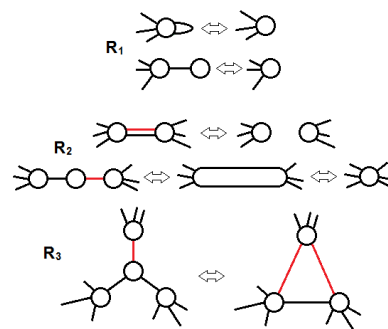

Figure 9: Reidemeister moves on graphs

The **R₃**-move results in removing or adding a node in a triangular region of a graph as indicated in the figure. The three edges involved in the move cannot be of the same parity.

The broken edges in figure 9 indicate that the node may, but not necessary, be connected to other nodes in the graph. Reidemeister moves can be combined to more complex moves. Figure 10 shows how a loop can move from one strand to the other. The corresponding graph moves are also given. These moves can be generalised in different ways and one way is illustrated in figure 11.

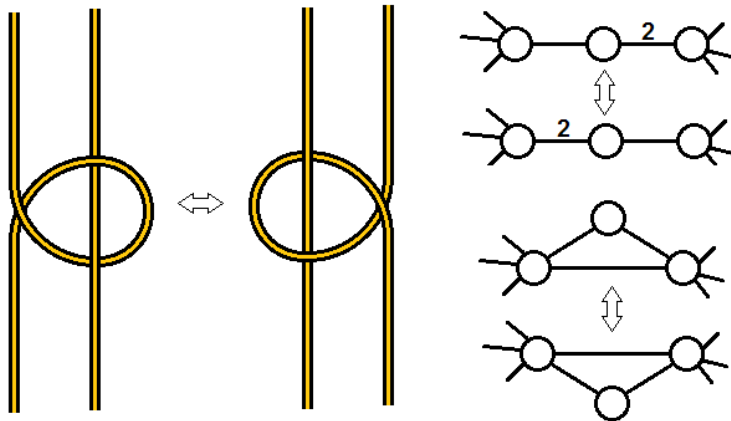

Figure 10: Jumping loop

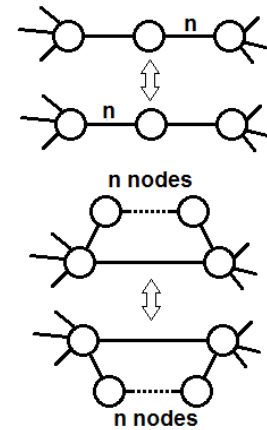

Figure 11: Generalisations of the jumping loop

The moves in figure 11 shows that a single edge followed by a multi-valued edge always can be interchanged, or in the other case, a sequence of edges can be moved from one side of a single edge to the other.

Figure 12 gives two examples of graphs where the jumping loop move is applied, thereby showing that the knots are the same, although in different projections. The two knots represented by graphs in this figure are denoted **7₅** and **7₆**, respectively (see appendix A).

In bi-coloured graphs there are many complex moves that can reduce the number of edges in a graph, thereby decreasing the number of crossings of the corresponding knot. One such move is shown in figure 13 where a loop is untwisted. These moves

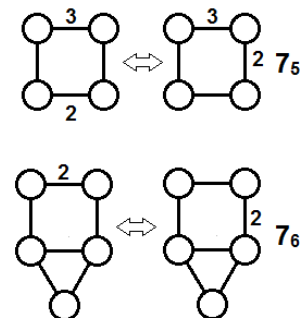

Figure 12: 2 knots represented by different graphs

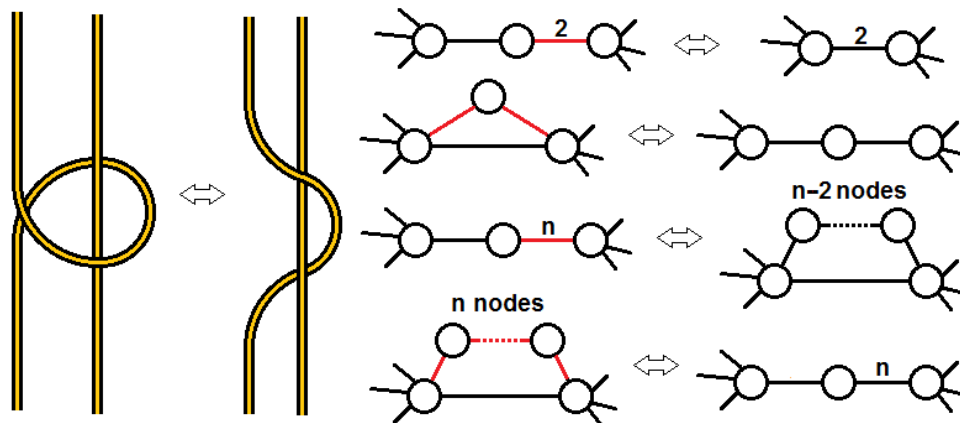

Figure 13: Untwisted loop

can also be generalised in various ways and the moves given at the lower right of the figure are examples. All these moves reduce the number of edges by one, and no graph containing any of the subgraphs to the left can represent knots in a minimal crossing-number projection.

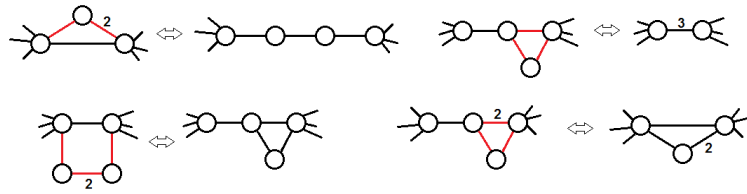

Figure 14: Edge-reducing moves

Figure 14 gives a few more moves that reduces the number of edges by one. Repeated usage of these and other moves give rise to the generalisation seen in figure 15. Here an arbitrary subgraph G can be interchanged with a single edge. Note that in the top part the subgraph is flipped over vertically and in the lower part the subgraph is flipped in the horizontal direction, as indicated by the orientation of the G s. In both cases the parities of all edges in G are conserved. These moves are normally referred to as ‘flypes’.

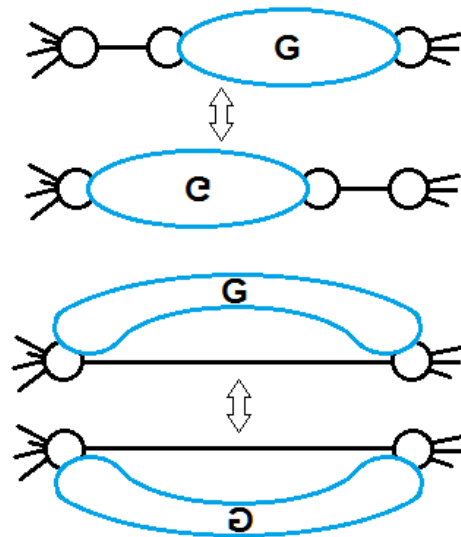

Figure 15: Generalisations

Two multi-valued edges, with the same parity, connected to a third node cannot be interchanged. In the subgraph, to the left in figure 16a, the double- and triple-edges cannot be interchanged. If the subgraph is bi-coloured (top right) the graph can be transformed but the number of edges cannot be decreased. In the subgraph at the lower middle the red edges cannot be moved on top of the black ones, but can be transformed in other ways. A few more useful moves are shown in fig 16b.

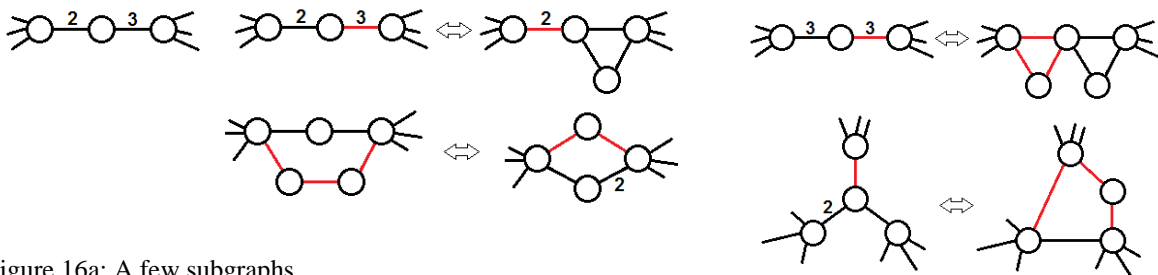

Figure 16a: A few subgraphs

Figure 16b: Some other useful moves

6. Bridges

In figure 17a we have a graph in which two nodes are connected to each other via three arbitrary subgraphs. We say that the two nodes are connected by three bridges. In figure 17b one of the nodes is expanded and moved over the whole graph as in figure 17c. Since the rim of a circular node correspond to a string piece in a knot this is the same procedure that was applied to the trefoil knot in figure 3. In figure 17d the edge between G_1 and the engulfing node is moved contraclockwise from right to left followed by the same movement of G_2 . The subgraph G_3 follows the same procedure but this time the movement goes clockwise. In figure 17e the

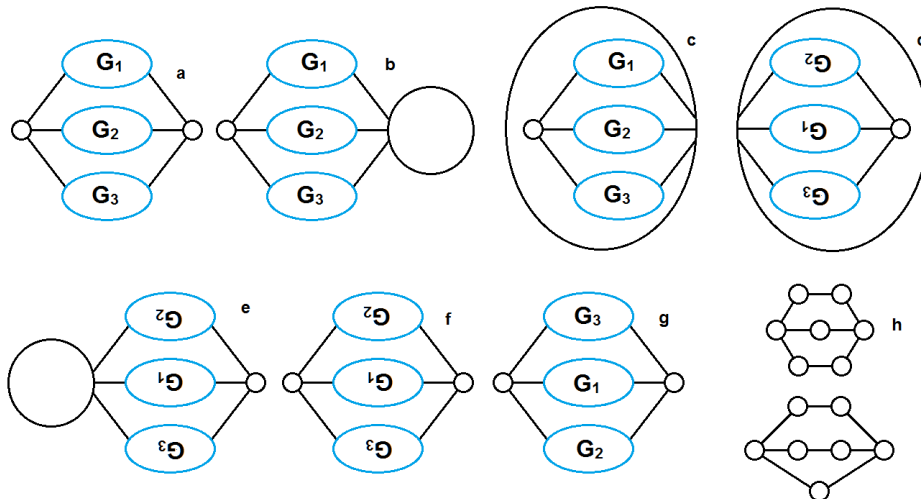

Figure 17: Bridges

expanded node is flipped back to the left and reduced to its original size (figure 17f). The graph is rotated to become the graph given in figure 17g. If the two graphs 17a and 17g now are compared, it is obvious that any cyclic permutation of the three bridges are allowed. Non-cyclic permutations will produce graphs that don't correspond to the same knot. The parities of all edges in the graph are conserved. Note that the edges connecting a node with a sub-graph may represent several edges connected to different nodes in the sub-graph. This procedure can be generalised to any number of bridges as long as the permutations are cyclic. The two graphs shown in figure 17h are thus both representations of the knot **8**₅.

7. Non-alternating knots

In appendix A all alternating knots having minimal crossing-numbers 8 or less are given together with their corresponding graphs. [8] There are one knot having 3 crossings, one with 4, two with 5, three with 6, seven with 7 and eighteen knots having 8 crossings. If we go through the corresponding graphs we will find that all the graphs corresponding to knots with 7 or fewer crossings cannot be bi-coloured without having the possibility to reduce one or more edges.

The same is true for most of the graphs corresponding to knots with 8 crossings. The only knots with could produce bi-coloured graphs are the six knots **8**₅, **8**₁₀, **8**₁₅, **8**₁₆, **8**₁₇ and **8**₁₈. Figure 18 summarises all possible bi-colourings of the graphs corresponding to these 6 knots. There are all together 17 possible bi-coloured graphs obtained not counting twin-graphs. Those 17 possibilities only correspond to 3 different knots; **8**₁₉, **8**₂₀ and **8**₂₁. These are the only 3 non-alternating knots with minimal crossing-number 8. For instance the graph denoted **8**₁₉₍₅₎ corresponds to knot **8**₁₉ in an **8**₅ projection. The two graphs **8**_{20(16')} and **8**_{20(16'')} are different colourings leading to the same knot **8**₂₀ in an **8**₁₆ projection. Figure 19 shows how **8**₁₉₍₅₎ can be transformed by an **R**₃-move to **8**₁₉₍₁₆₎ and how **8**₁₉₍₁₆₎ similarly becomes **8**₁₉₍₁₈₎.

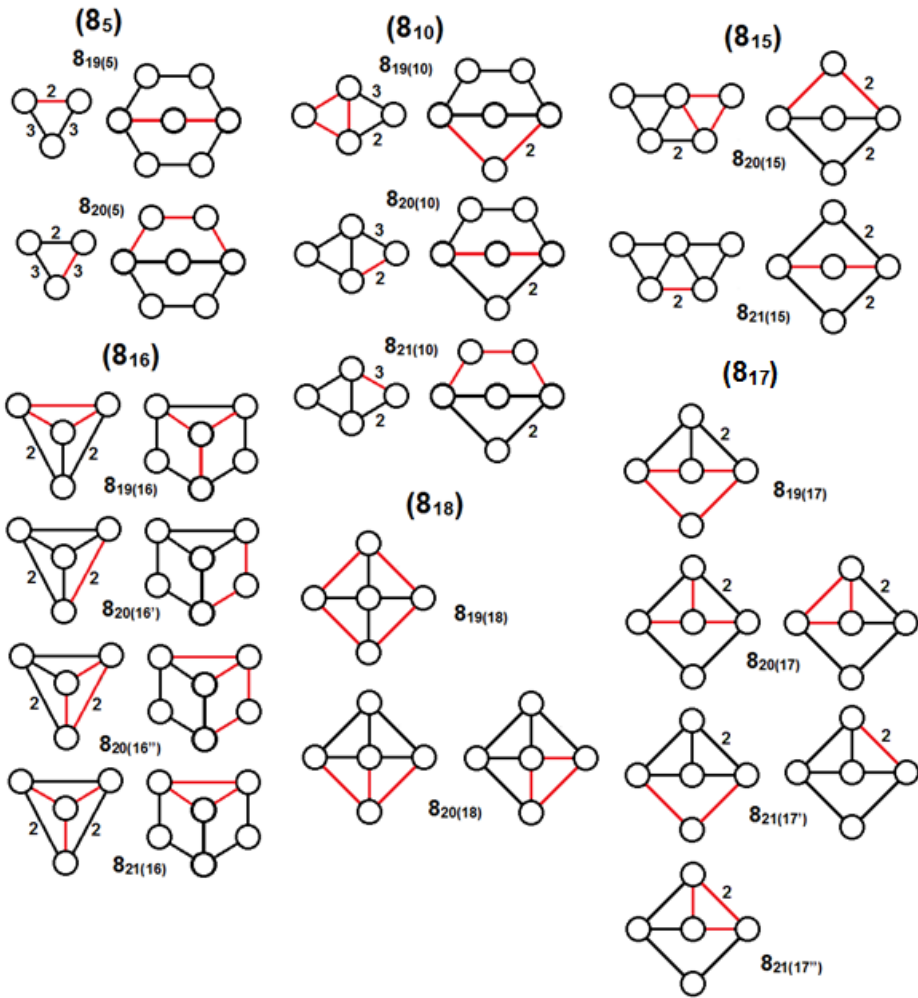

Figure 18: Colourable graphs with 8 edges

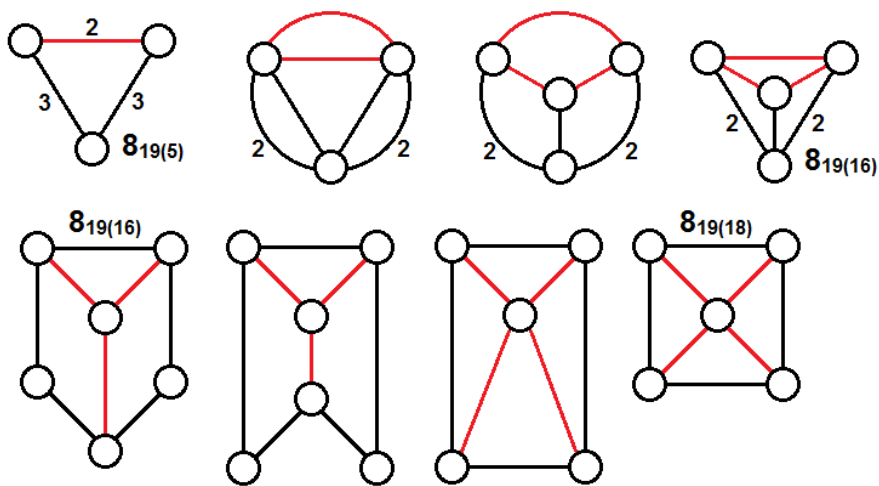

Figure 19: Transformations of graphs corresponding to knot 8_{19} .

8. Knots with 9 crossings

In appendix C we show all 49 knots having a minimal crossing-number of 9. Since the total number of regions for a knot with n crossings is $n+2$, which corresponds to the total number of nodes in the two twin-graphs, it will always be possible to find a graph with m nodes where $m \leq n/2 + 1$. For knots with 9 crossings this means that a graph with 5 or less nodes must exist. Its twin-graph then has to have at least 6 nodes to make a total of 11. Only the graphs with the smallest number of nodes are given in appendix C. Out of the 49 knots 41 are alternating and 8 non-alternating (942 – 949). For the non-alternating knots only one possible graph is given chosen randomly out of the many possibilities (c.f. non-alternating knots with 8 crossings). All graphs in appendix C have twin-graphs with at least 6 nodes. It is left to the reader to work them out.

9. Prime knots and composite knots

All knots regarded so far are prime knots. Prime knots can be added together to make composite knots. The simplest composite knots are achieved by adding two trefoil knots either two with the same parity or two with different parities. Figure 20 shows the resulting knots and some corresponding graphs. The knot to the left is called the Granny knot and the one to the right is called the Square knot. [9] If a graph can be cut into two halves by cutting through a single node, as indicated in the bottom of the figure, the corresponding knot is always a composite knot. Any two or more prime knots can be combined in similar ways to produce composite knots. Graphs corresponding to composite knots can be treated in essentially the same ways as those corresponding to prime knots.

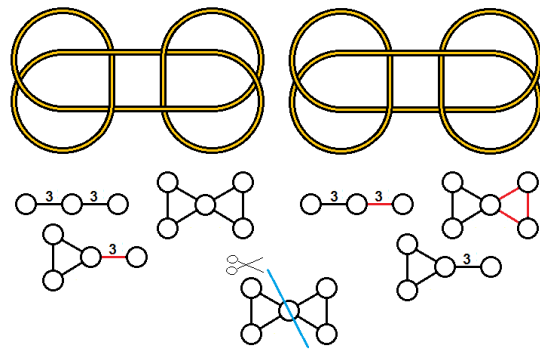

Figure 20: The Granny knot and the Square knot

10. Links

Not all planar, connected graphs will correspond to knots. Several rings of strings which are entangled with each other are called links [1,2,3]. A knot is just a link made up of one string

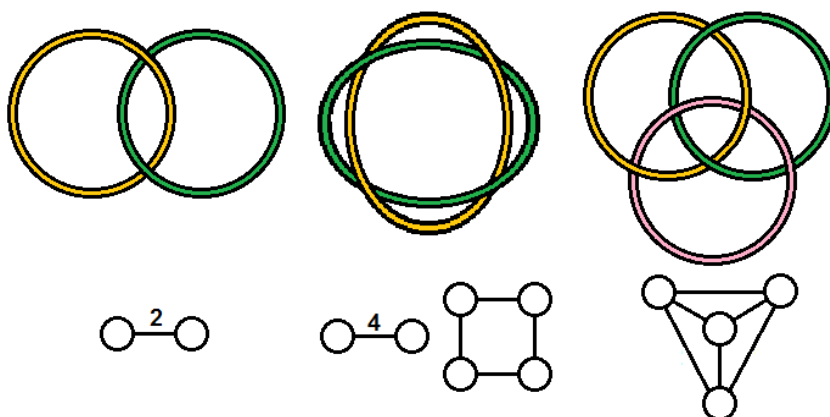

Figure 21: Some links

ring. Figure 21 gives a few examples of links together with their corresponding graphs. The link to the left is called the Hopf link, the link to the right is called the Borromean rings and the link in the middle is sometimes called Solomon's knot. [9]

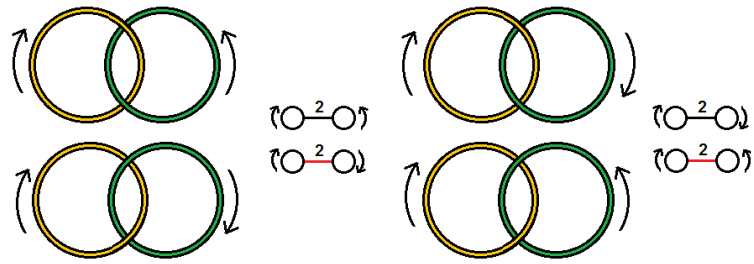

Figure 22a: The Hopf pair

Sometimes it is necessary to consider the orientation of the links, e.g. the Hopf link can be

divided into a pair. In figure 22a the Hopf pair is shown together with its corresponding graphs. The link to the right cannot be transformed into the link to the left if the orientation is to be conserved.

In figures 2 and 3 we introduced elongated X-es and how they became black and red edges in the corresponding graphs. When we consider oriented knots and links each edge or bundle has to be given a sign to differentiate cases where the two legs in an X points in the same direction or not. The four different cases are depicted in figure 22b. Note that the signs do thus not indicate the parities of the edges (indicated by colour) but the orientation of how the strands cross.

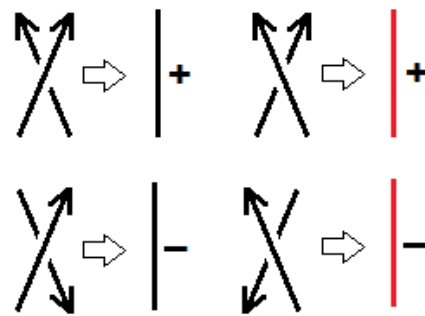

Figure 22b: Oriented crossings

11. Planar connected graphs

Up to now we have seen that knots can be represented with planar connected graphs. If we consider prime knots in their minimal crossing-number projection, each node in a graph has to have at least 2 connections (with exception for the graph in figure 6 describing the trefoil knot). The graphs are said to have a minimal degree of 2 [4]. There are one such graph with 3 nodes, three with 4 nodes and 10 with 5 nodes. All these graphs are shown in figure 23, where the graphs are denoted with the number of nodes and edges. Graph 5:6c will lead to composite knots, whereas the rest of the graphs are all used to represent knots in appendices A and C. The 49 planar 2-connected graphs with 6 nodes are given in appendix I.

In figure 24 the two graphs to the left both correspond to knot **9₂₈** (twin-graphs to the graph given in appendix C). The blue part can be attached to the rest of the graph in two ways. The two graphs in the middle will, however, correspond to different knots. Those graphs correspond to knots **11a₄₇** and **11a₄₄**, respectively, using the Hoste-Thistlethwaite notation [8]. This illustrates that all types of planar, connected graphs with a minimal degree of 2 are needed to describe some knots.

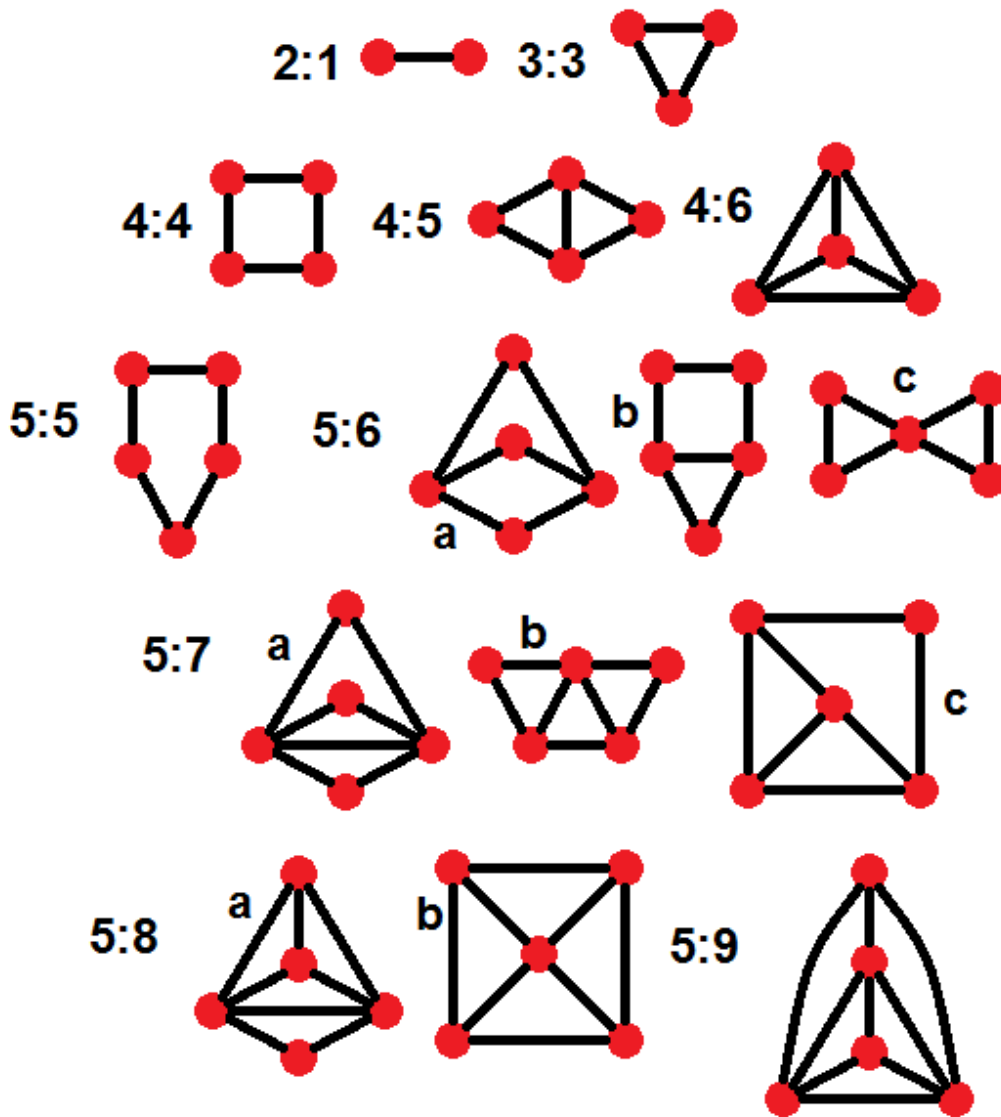

Figure 23: Planar connected graphs with a minimal degree of 2

The two graphs to the right are different projections of the same graph, but the corresponding knots are different. This illustrates that different forms of the same graph may correspond to different knots. Those two graphs correspond to knots **11a57** and **11a231**, respectively. Here the four bridges are permuted in a non-cyclic way (c.f. section 6).

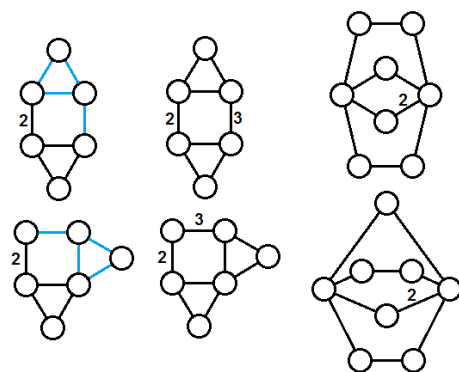

Figure 24: A few graphs

12. From graph to knot

So far we have only considered how knots can be represented by graphs. Can this process be reversed? Yes it can. Figure 25 shows how a graph representing a projection of the knot **9₂₄** can be transformed into the corresponding knot. Each edge in the graph is marked with elongates X-es, their number corresponding to the multiplicity of each edge. Since all edges here have the

same parity, all X-es will be the same (c.f. section 3). Subsequently the X-es are connected following the outline of the original graph, making sure that none of the edges of the original graph is crossed. The five nodes of the graph can now easily be recognised as five regions of the knot. Finally the corners are rounded of and an image of the knot is produced in the projection indicated by the original graph. Any graph can be treated in the same way to produce the corresponding knot.

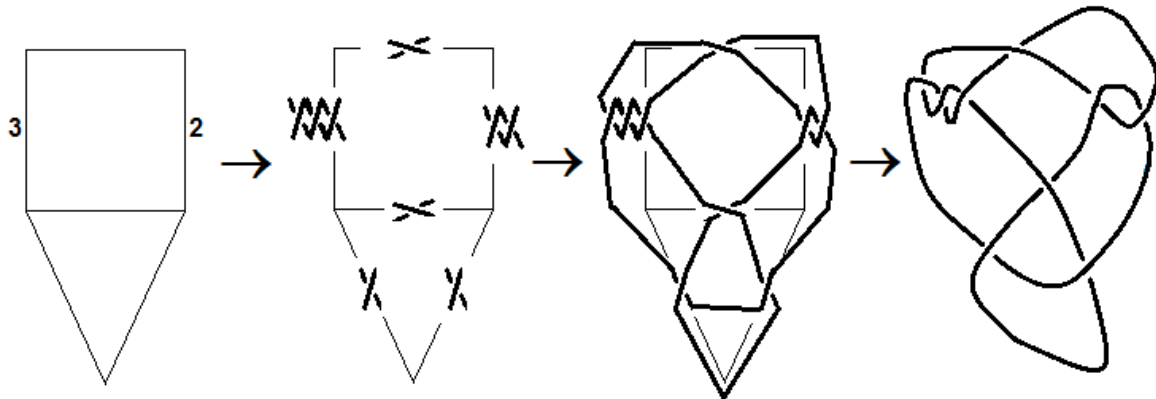

Figure 25: From graph to knot for a projection of the knot **9₂₄**.

13. A few practical demonstrations

In figure 26 we see two different knot projections together with their corresponding graphs. What can be deduced about the two knots? In figure 27 the nodes in the graph to the left of figure 26 are labelled with letters so that the transformations can be followed more easily. First we blow the graph up showing that the nodes *c* and *d* are connected via three bridges. We make a bridge move as in figure 17 and move the lower bridge to the

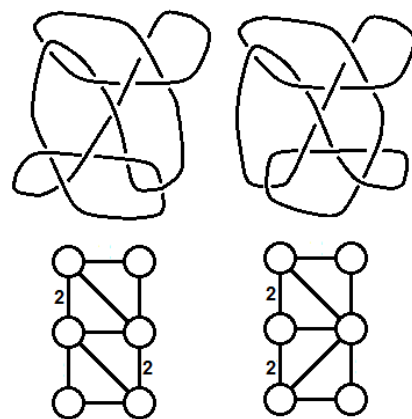

Figure 26: Two knots and their graphs

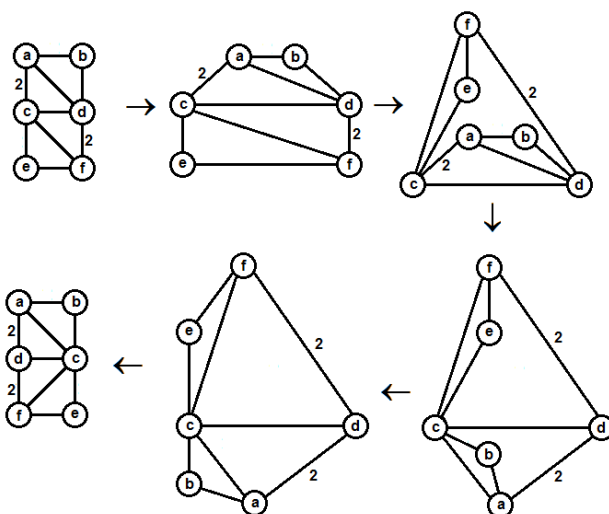

Figure 27: The two knots are the same

top. Next we take the bridge with the nodes *a* and *b* and move it below the single edge *cd* according to the move discussed in the context of figure 15, remembering to flip this bridge horizontally. Finally the nodes *b* and *e* are moved to the outside of the graph (as indicated in figure 10). After rotating the graph 180° we have arrived at the graph to the right in figure 26, thus showing that the two knots are different projections of the same knot, namely knot **11a₁₄**.

move removing the h-node. The two edges between the f- and c-nodes can now be eliminated by an \mathbf{R}_2 -move. We are now left with 11 edges. Next we remove the g-node followed by the f-node by two \mathbf{R}_3 -moves. The red edge between the e- and d-nodes can now be moved to the other side of the graph by a bridge move. The two edges connecting the e- and d-nodes can now be eliminated by an \mathbf{R}_2 -move, reducing the number of edges to 9. We now move the b-node over the edge connecting the c- and a-nodes, and using one of the edge-reducing moves in figure 13, the e-node is eliminated. We are now left with 8 edges. One red and one black edge between the c- and a-nodes are eliminated bringing the number of edges down to 6.

Now we move the b-node back to the outside of the graph and through an \mathbf{R}_3 -move we insert a new node e. The b-node can now be removed together with its edge by an \mathbf{R}_1 -move, reducing the number of edges to 5. Now the c-node can be removed using one of the edge-reducing moves in figure 13 followed by the same move removing the d-node. The only thing remaining now are two nodes connected by three edges; two black and one red. Two of the edges are removed by an \mathbf{R}_2 -move and finally the e-node is chopped off by an \mathbf{R}_1 -move.

We are now left with a single unconnected node, which corresponds to the unknot, normally denoted $\mathbf{0}_1$, showing that the original knot wasn't knotted at all.

14. The Perko pair

All minimal projections of non-alternating prime knots with up to 10 crossings can rather effortlessly be found using Reidemeister moves and the useful moves given in figure 16. There is however one exception to this, namely the knot $\mathbf{10}_{161}$. All minimal projections of this knot are given in graph form in figure 29. The number below each graph indicates the corresponding uni-coloured knot graph and the graphs with 6 nodes are given together with their twin graphs. When the twins are the same an asterisk is added to the number. The projections are divided into two groups, and although it is trivial to transform one projection to another one within the same group, it is nontrivial to make transformations between the two groups. Thus the two groups were for a long time considered as two distinct knots. In 1973 Ken Perko showed that the two knots actually were different projections of the same knot [10]. Figure 30 shows how the projection $\mathbf{10}_{161(109)}$ is transformed into the projection $\mathbf{10}_{161(107)}$ using a sequence of \mathbf{R}_1 - and \mathbf{R}_3 -moves, thereby corroborating Perko's finding.

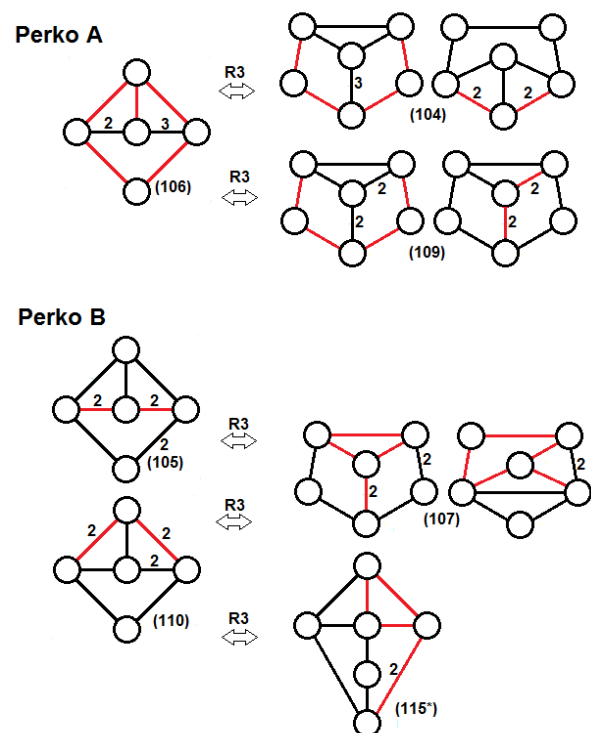

Figure 29: Projections of the Perko knot

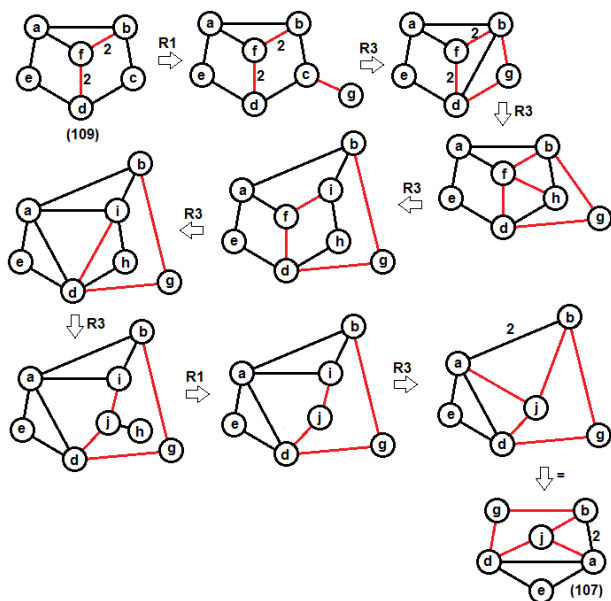

Figure 30: Transformation of $10_{161}(109)$ into $10_{161}(107)$

15. The complexity of non-alternating prime knots

In previous sections we have studied graphs corresponding to both alternating and non-alternating prime knots. It is seen that alternating knots in their minimal crossing projections are rather straightforwardly described by graphs with only few variations. When we consider non-alternating knots the number of variations, corresponding to different projections can be very large. Figure 31 shows graphs corresponding to different minimal crossing projections of the knot $11n38$. Note that to each of those graphs there is a twin-graph with 7 or more nodes (not shown). The numbers within brackets below each graph refer to the corresponding alternating knot graph.

16. The HOMFLY-polynomial

There are many different ways to define invariants for knots which will be the same independent of the specific projection of a knot [11].

One of the most successful invariants is the HOMFLY-polynomial [12]. The HOMFLY-polynomials exist in slightly different versions

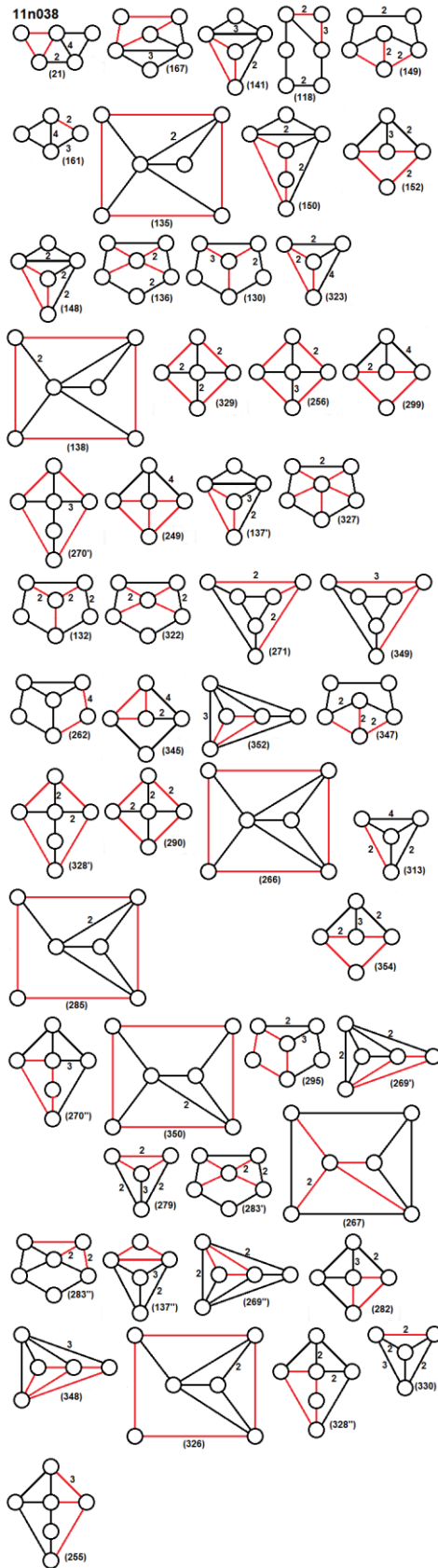

Figure 30: Various forms of $11n38$

where the version used here is obtained by the following rules:

1. $P(\text{unknot}) = 1$ in all its projections
2. $aP(L_+) - a^{-1}P(L_-) = zP(L_0)$

Here L_+ , L_- and L_0 refer to local changes of a knot projection keeping the rest of the projection intact. The changes are illustrated in figure 31a. These changes have their counterparts in graphs, but here we have to differentiate between two cases; $+$ -edges and $-$ -edges as defined in section 10 (fig. 22b). This is shown in figure 32b. Note that if the edge has positive (negative) orientation, two nodes are fused (separated) with the L_0 -change. Using the rules repeatedly gives the HOMFLY-polynomial for the trefoil knot

$$P(\text{trefoil}) = z^2 a^{-2} + 2a^{-2} - a^{-4}$$

and its mirror knot is obtained by substituting a by a^{-1} . The figure-8 knot has the polynomial

$$P(\text{figure-8}) = -z^2 + a^2 - 1 + a^{-2}$$

Here the substitution will produce the same expression indicating that that the two mirror images are the same. Some types of knots can be given general expressions for their HOMFLY-polynomials. All knots of the form in figure 32 are given by

$$P = \mathcal{F}(n) \equiv a^{-4} \mathcal{G}(n+2) - \mathcal{G}(n)$$

where

$$\mathcal{G}(n) \equiv (-z)^{n-1} a^{n+1} \sum_{k=0}^{\lfloor n/2 \rfloor} \binom{n-k-1}{k-1} z^{-2k} \quad \text{for } n \geq 0$$

$$\text{and } \mathcal{G}(n) \equiv a^{2n-2} \mathcal{G}(-n+2) \quad \text{for } n < 0$$

This expression is also valid for 2-component links when n is even.

As an example, for $n = 11$ we obtain

$$P = z^{10} a^{10} + z^8 (10a^{10} - a^{12}) + z^6 (36a^{10} - 8a^{12}) + z^4 (56a^{10} - 21a^{12}) + z^2 (35a^{10} - 20a^{12}) + (6a^{10} - 5a^{12})$$

Three-bundle knots or triangular knots can be divided into two types as illustrated in figure 33. The general expression for type A is

$$P = \mathcal{T}(n_1, n_2, n_3) \equiv a^{-n_1-n_2} + a^{-n_1-n_3} + a^{-n_2-n_3} - a^{-n_1-n_2-n_3+1} - a^{-n_1-n_2-n_3-1} + z^{-1} \{ a \mathcal{H}(n_1+1) \mathcal{H}(n_2+1) \mathcal{H}(n_3+1) - a^{-1} \mathcal{H}(n_1-1) \mathcal{H}(n_2-1) \mathcal{H}(n_3-1) \}$$

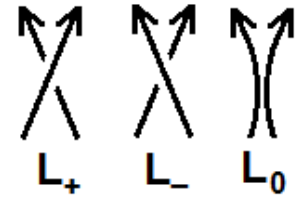

Figure 31a: Lokal changes in a projection

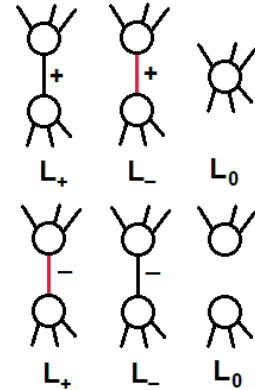

Figure 31b: Lokal changes in a graph

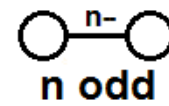

Figure 32: One-bundle knots

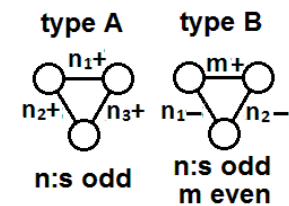

Figure 33: Three-bundle knots

where

$$\mathcal{H}(m) \equiv z \sum_{k=1}^{m/2} a^{-2k+1} \quad \text{for } m \text{ even, } m \geq 0$$

$$\text{and } \mathcal{H}(m) \equiv -z \sum_{k=1}^{-m/2} a^{2k-1} \quad \text{for } m \text{ even, } m < 0$$

The general expression for type B is

$$P = a^{-m} \mathcal{F}(n_1) \mathcal{F}(n_2) + \mathcal{F}(n_1 + n_2) \mathcal{H}(m)$$

where the functions \mathcal{F} and \mathcal{H} are defined above.

Examples for type A and B, with the graphs given in figure 34, are

$$P(G1) = z^2(a^{-2} + 2a^{-4} + 3a^{-6} + 4a^{-8} + 4a^{-10} + 3a^{-12} + a^{-14}) + (a^{-8} + a^{-10} + a^{-12} - a^{-14} - a^{-16})$$

$$P(G2) = -z^2(a^2 + 3 + 3a^{-2} + 2a^{-4} + a^{-6}) + (a^4 + a^2 - 1 - a^{-2} + a^{-8})$$

$$P(G3) = -z^{10}a^8 + z^8(a^{10} - 9a^8 + a^6) + z^6(7a^{10} - 30a^8 + 8a^6) + z^4(16a^{10} - 47a^8 + 22a^6) + z^2(14a^{10} - 37a^8 + 24a^6) + (5a^{10} - 18a^8 + 9a^6)$$

$$P(G4) = z^8a^{-2} - z^6(1 - 8a^{-2} + a^{-4}) - z^4(6 - 23a^{-2} + 6a^{-4}) - z^2(11 - 28a^{-2} + 11a^{-4}) - (5 - 12a^{-2} + 6a^{-4})$$

Alexander, Conway and Jones polynomials can be derived from the HOMFLY-polynomial with the following substitutions:

$$\text{Alexander } \Delta(t): a \rightarrow 1; \quad z \rightarrow t^{1/2} - t^{-1/2}$$

$$\text{Conway } \nabla(z): a \rightarrow 1$$

$$\text{Jones } V(q): a \rightarrow q^{-1}; \quad z \rightarrow q^{1/2} - q^{-1/2}$$

Note that although the HOMFLY-polynomial is the same for all projections of the same knot, different knots can have the same polynomial. I.e. there are knots that cannot be distinguished by the HOMFLY-polynomial. As an example, the two distinct knots with 13 crossings shown in figure 35, have the same HOMFLY-polynomial.

17. Knot genus

In topology different kind of surfaces are assigned genera [12]. E.g. a sphere has genus 0 and a torus has genus 1. Knots can also be assigned a genus [13] which is also an invariant of the knot. The genus of a knot is defined as the smallest genus of any of its projections. For alternating prime knots it is enough to calculate the genus for any minimal projection, but for non-alternating knots the procedure can be quite cumbersome since the number of projections that have to be considered can be very large (c.f. fig 30). The only knot with genus 0 is the unknot. We are not giving the details here, but in fig. 36 all types of knots with 5 or fewer bundles are given and below general genera for those types are given.

Note that the types 3A and 5D have genera which are independent of the number of crossings. Types of knots with 6 or 7 bundles, sharing this feature, are illustrated in fig. 37. Such types are those where all crossings are positive.

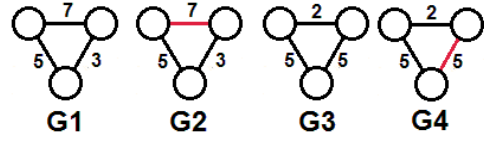

Figure 34: Examples of three-bundle knots

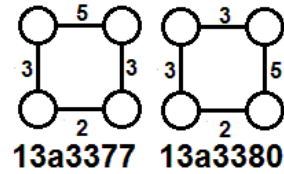

Figure 35: The knots 13a3377 and 13a3380

$$\begin{aligned}
1: & \quad g = \frac{n-1}{2} \\
3A: & \quad g = 1 \\
3B: & \quad g = \frac{n_1+n_2}{2} \\
4: & \quad g = \frac{m+n_1+n_2+n_3-3}{2} \\
5A: & \quad g = \frac{m+n_4+1}{2} \\
5B: & \quad g = \frac{m_1+n_1+n_2+n_3-1}{2} \\
5C: & \quad g = \frac{n_1+n_2+n_3+1}{2} \\
5D: & \quad g = 2 \\
5E: & \quad g = \frac{n_1+n_2+n_3+n_4-2}{2}
\end{aligned}$$

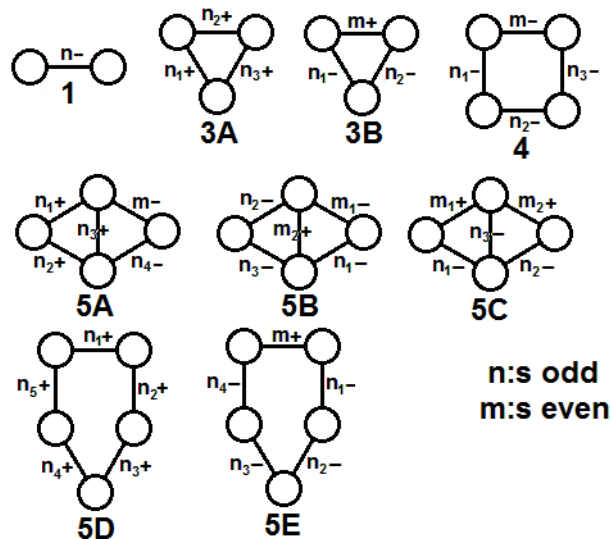

Figure 36: Knot types with 5 or fewer bundles.

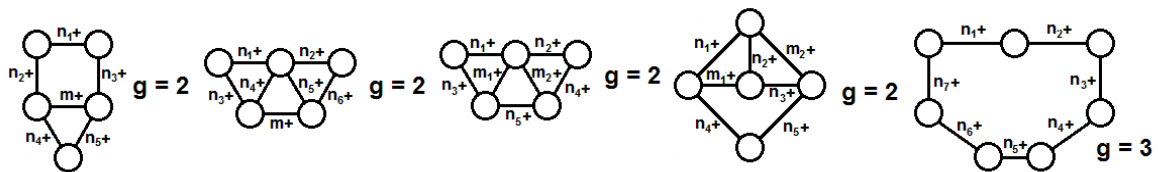

Figure 37: Knot types with 6 or 7 bundles with fixed genera.

18. Summary

In this note we have demonstrated that any knot or link can be represented by a planar, connected graph with multiple edges, so called bundles. Furthermore any conceivable projection of a knot can be represented by such a graph. The total number of edges in a graph correspond to the number of crossings of the knot. In the same way as one projection of a specific knot can represent all projections of that knot, one of the graphs representing the knot can be chosen to represent all its variations. Since a graph conserves all the features of a specific knot, a table of knots can be condensed into a table of graphs. At the very least, planar connected graphs can be used as symbols for the knots.

Appendix D contains all graphs with 6 or fewer nodes that correspond to all alternating prime knots with crossing number 11 or less. Appendix E contains all graphs with 5 or fewer nodes that correspond to alternating prime knots with crossing number 12. Appendix F contains all graphs with 6 nodes that correspond to alternating prime knots with crossing number 12, and finally appendix G contains all graphs with 7 nodes that correspond to alternating prime knots with crossing number 12 or less. Note that all graphs in those appendices represent an infinite number of alternating prime knots, since any odd bundle can take any odd number and any even bundle can take any even number. An additional appendix (H) is included with graphs corresponding to all prime links with crossing number 9 or less.

References

- [1] A fairly recent overview of knot theory is Adams, C C (2004), *The Knot Book: An Elementary Introduction to the Mathematical Theory of Knots*, American Mathematical Society, ISBN 0-8218-3678-1
- [2] On the web, Wikipedia has a lot of related articles, e.g. http://en.wikipedia.org/wiki/Knot_theory and [http://en.wikipedia.org/wiki/Knot_\(mathematics\)](http://en.wikipedia.org/wiki/Knot_(mathematics)) where links lead to other related pages.
- [3] Wolfram MathWorld has a lot of related articles, where a good starting point is [Weisstein, Eric W.](http://mathworld.wolfram.com/Knot.html) "Knot." From *MathWorld*--A Wolfram Web Resource. <http://mathworld.wolfram.com/Knot.html>
- [4] See, for instance [Weisstein, Eric W.](http://mathworld.wolfram.com/PlanarConnectedGraph.html) "Planar Connected Graph." From *MathWorld*--A Wolfram Web Resource. <http://mathworld.wolfram.com/PlanarConnectedGraph.html>
- [5] This is the Alexander-Briggs notation of knots commonly used for knots with 10 crossings or less. See [1,2,3].
- [6] <http://www.knotplot.com/>
- [7] Owing to Reidemeister, Kurt (1926) *Elementare Begründung der Knotentheorie*, Abh. Math. Sem. Univ. Hamburg 5. See [1,2,3].
- [8] All prime knots with 11 crossings or fewer can be found in the Knot Atlas. http://katlas.org/wiki/Main_Page
All prime knots with 12 crossings or fewer can be found at Knotinfo <http://www.indiana.edu/~knotinfo/>
- [9] See, for instance http://en.wikipedia.org/wiki/List_of_mathematical_knots_and_links
- [10] Kenneth A. Perko Jr, *On the classification of knots*. Proc. Amer. Math. Soc. 45 (1974), 262—266.
See, for instance https://en.wikipedia.org/wiki/Perko_pair
- [11] See, for instance https://en.wikipedia.org/wiki/Knot_invariant
- [12] Freyd, P., Yetter, D., Hoste, J., Lickorish, W.B.R., Millett, K., and Ocneanu, A. (1985). *Bulletin of the American Mathematical Society* **12** (2): 239–246
See, for instance https://en.wikipedia.org/wiki/HOMFLY_polynomial
- [13] See, for instance [https://en.wikipedia.org/wiki/Genus_\(mathematics\)](https://en.wikipedia.org/wiki/Genus_(mathematics))
- [14] See, for instance https://en.wikipedia.org/wiki/Seifert_surface